

The Impressor

The Barcol Impressor Hand-Held Portable Hardness Tester

- Aluminum
- Aluminum Alloys
- Soft Metals
- Plastics
- Fiberglass



Introduction

Portable

The Impressor is a convenient tool for testing the hardness of aluminum, aluminum alloys, copper, brass and other materials including plastics and fiberglass. The instrument is designed for use on fabricated parts and assemblies as well as on raw stock.

Easy to Use

No experience required; can be used in any position and in any space that will allow for the operator's hand. The hardness reading is instantly indicated on the dial, which is divided into one hundred graduations. No waiting, pre-loading or separate measurements.

Lightweight

The impressor weighs only 1 lb. 2 oz. and comes complete with carrying case, adjusting wrench and two spare indenter points, 2 lb. 8oz.

Applications

Four Models Available

GYZJ 934-1 for soft metals such as aluminum and its alloys, brass, copper, and some of the harder plastics and fiberglass. Approximate range 25 to 150 Brinell (10 mm ball 500 kg load). This unit meets American Society for Testing and Materials (ASTM) Standard D-2583.

GYZJ 934-1-0-1 for ladder testing. Compliant with **NFPA 1932**, National Fire Protection Association – 1994 Edition; **ASTM B648-76**, American Society for Testing and Materials – 1984 edition.

GYZJ 935 for the softer plastics and very soft metals.

GYZJ 936 for extremely soft materials such as lead, linoleum and leather.

Our engineers will be glad to recommend the most suitable model upon receipt of sample materials.

Operating Information

The Impressor is best suited for testing homogeneous materials. Materials of granular, fibrous or coarse structure will produce a wide variation in hardness readings because of the small diameter of the indenter point.

For accurate readings, material should be at least 1/32" thick and large enough for a minimum distance of 1/8" in any direction from the indenter point to the edge of the specimen. The testing area should be smooth and free from mechanical damage.

Simply exert a light pressure against the instrument to drive the spring-loaded indenter point into the material. The indenter point must be perpendicular to the surface being tested.

On very soft metals, the highest reading should be used since cold flow permits the spring-loaded indenter point to continue penetration.

The Impressor

Operating Information (continued)

Note: Physical characteristics of very soft materials are such that uniform correlation between different hardness measuring systems cannot be established. For this reason, no conversion curves are offered for the 935 and 936 models. We recommend that impressor hardness limits for each material be established by test.

Recommended Sample Sizes To equalize the variance of the average (GYZJ 934-1)

	Hardness Scale	Reading Variance	Number of Readings	Variance of Average
Homogeneous Material:	20	2.47	9	0.27
	30	2.20	8	0.28
	40	1.93	7	0.27
	50	1.66	6	0.28
	60	1.39	5	0.28
	70	1.12	4	0.28
	80	0.85	3	0.28
Reinforced Plastics:	30	22.4	29	0.77
	40	17.2	22	0.78
	50	12.0	16	0.75
	60	7.8	10	0.78
	70	3.6	5	0.75

Typical Readings of Aluminum Alloys

Alloy and Temper:	1100-0	3003-0	3003H14	2024-0	5052-0	5052H14	6061T6	2024T3
GYZJ 934-1 reading:	35	42	56	60	62	75	80	85

Approximate Conversion Curves for GYZJ 934-1

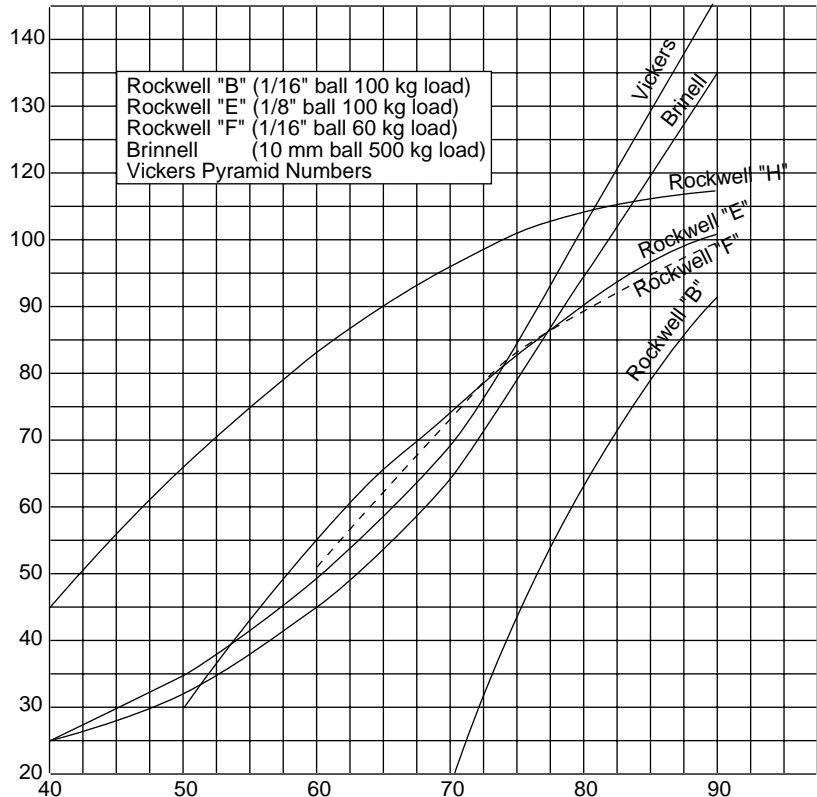

The Impressor

Operating Information (continued)

Approximate Conversion Chart for GYZJ 934-1

934-1	Brinnell	Vickers	Rockwell			
			B	E	F	H
35		23				32
36		23				33
37		24				37
38		24				40
39		25				43
40	25	25				45
41	26	26				47
42	26	27				49
43	27	27				52
44	27	28				54
45	27	20				56
46	28	30				58
47	29	32		24		61
48	30	33		25		63
49	31	34		28		64
50	32	35		30		66
51	33	36		33		68
52	34	38		36		70
53	35	39		39	29	72
54	37	41		42	33	73
55	38	42		44	38	75
56	39	44		46	40	76
57	40	45		48	43	78
58	42	47		51	47	80
59	44	48		53	49	81
60	45	49		55	51	83
61	47	51		57	54	84
62	48	53		59	56	86
63	50	55		62	58	88
64	52	57		64	61	89
64	54	58		65	63	90
66	55	60		67	65	91
67	58	62		69	67	92

934-1	Brinnell	Vickers	Rockwell			
			B	E	F	H
68	60	64		71	69	94
69	62	67		73	71	95
70	64	69	18	74	73	96
71	67	72	19	76	75	98
72	69	74	28	77	77	99
73	71	76	33	79	79	100
74	73	81	39	81	81	101
75	76	85	45	83	83	102
76	80	88	48	84	84	103
77	84	92	52	86	86	104
78	87	95	56	88	87	105
89	90	99	60	89	88	106
80	94	103	63	90	89	107
81	97	108	65	91	90	108
82	100	111	69	92	91	108
83	105	116	72	94	92	109
84	109	122	75	95	93	109
85	113	127	77	96	94	110
86	117	133	80	97	95	111
87	122	137	83	98	96	111
88	126	142	86	99	97	112
89	131	144	89	100	97	112
90	135		91	101	98	113
91	139			102	99	113
92	145			103	100	
93				103	101	
94				104	101	
95				104	102	
96				105	102	
97				106	103	
98				107		
99				108		
100				108		

Approximate Conversion Chart GYZJ-935 and GYZJ-936

GYZJ-935 & 936	Type D Duramer	
	GYZJ-935	GYZJ-936
4	64	52
6	65	
8		66
10	67	
12		68
14	69	
16		70
18	71	
20		72
22	73	
24		74
26	75	
28		76

GYZJ-935 & 936	Type D Duramer	
	GYZJ-935	GYZJ-936
30	70	60
32		71
34	72	
36		73
38	74	
40		75
42	76	
44		77
46	78	
48		79
50	80	
52		81
54	82	
56		83

GYZJ-935 & 936	Type D Duramer	
	GYZJ-935	GYZJ-936
58	78	72
60	79	73
62		74
64	80	75
66	81	76
68	82	77
70		78
72	83	79
74	84	80
76	85	81
78		83
80	86	84
82	87	85
84	88	86
86	89	87
88	n/a	89

The Impressor

Ordering Information

Hardness Tester

Model	Range
GYZJ-934-1	25 to 50 Brinell (10 mm ball 500 kg load)
GYZJ-934-1-0-1	For ladder testing (NFTA and ASTM compliant)
GYZJ-935	For softer plastic and very soft metals
GYZJ-936	For extremely soft material

Certified Test Disks

Part No.	Use with Model	Barber-Colman Scale
GYZJ-069-100	Set of 5 GYZJ-935	87 – 89
GYZJ-070-100	Set of 5 GYZJ-936	48 – 50
GYZJ-078-100	Set of 5 GYZJ-934-1	43 – 48
GYZJ-250-100	Set of 5 GYZJ-934-1	87/89

Non-certified Test Disks

GYZJ-069	Each GYZJ-935	87 – 89
GYZJ-070	Each GYZJ-936	48 – 50
GYZJ-078	Each GYZJ-934-1	43 – 48
GYZJ-250	Each GYZJ-934-1	87/89

The Impressor Repair Parts

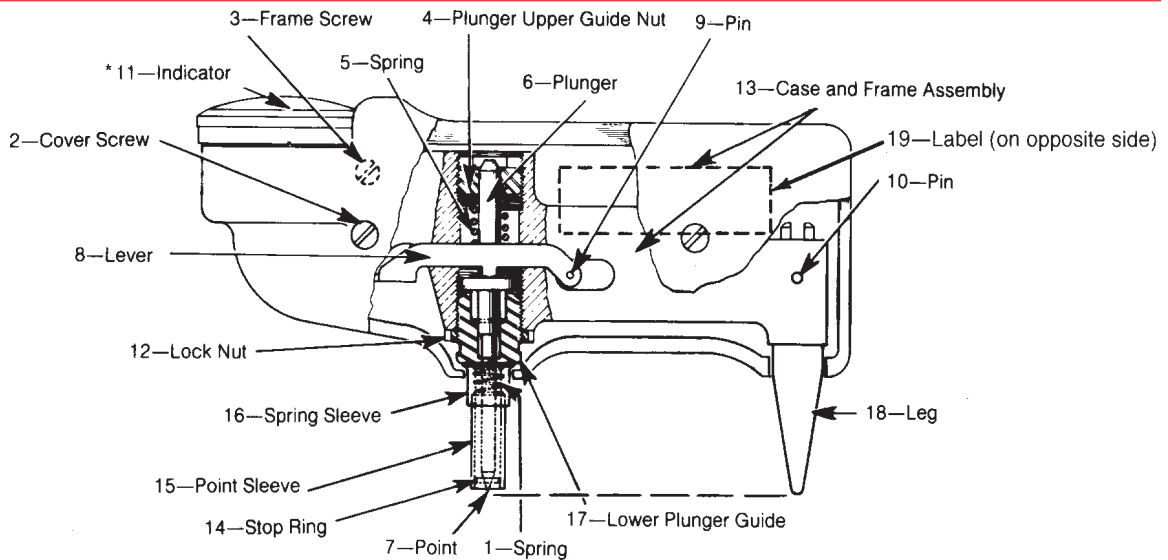

Item	GYZJ-934-1	GYZJ-935	GYZJ-936	Description	Qty
1	AYRS-62	AYRS-62	AYRS-62	Spring	1
2	BYRF-3114	BYRF-3114	BYRF-3114	Cover Screw	2
3	BYRF-250	BYRF-250	BYRF-250	Frame Screw	1
4	GYZJ-2	GYZJ-2	GYZJ-2	Plunger Upper Guide Nut	1
5	GYZJ-3	AYRS-146-1	AYRS-146-1	Spring†	1
6	GYZJ-4-1	GYZJ-4-1	GYZJ-4-1	Plunger	1
7	GYZJ-6-5	GYZJ-6-5	GYZJ-67	Indenter Point†	1
8	GYZJ-7	GYZJ-7	GYZJ-7	Lever	1
9	GYZJ-8	GYZJ-8	GYZJ-8	Pin	1
10	DYRA-218	DYRA-218	DYRA-218	Pin	1
11	GYZJ-15-2	GYZJ-15-2	GYZJ-15-2	Indicator (not field servicable)	1
12	GYZJ-16	GYZJ-16	GYZJ-16	Lock Nut	1
-	GYZJ-17-1	GYZJ-17-1	GYZJ-17-1	Wrench	1
-	GYZJ-19-2	GYZJ-19-2	GYZJ-19-2	Carrying Case	1
13	GYZJ-23-1	GYZJ-23-1	GYZJ-23-1	Case & Frame Assembly	1
14	GYZJ-61	GYZJ-61	GYZJ-61	Stop Ring	1
15	GYZJ-62	GYZJ-62	GYZJ-62	Point Sleeve	1
16	GYZJ-63	GYZJ-63	GYZJ-63	Spring Sleeve	1
17	GYZJ-64	GYZJ-64	GYZJ-71	Lower Plunger Guide†	1
18	GYZJ-65	GYZJ-65	GYZJ-65	Leg	1
18	GYZJ-65-4	For Model GYZJ-934-1-0-1 only		Leg	1
19	GYZJ-79-1	GYZJ-79-2	GYZJ-79-3	Label†	1

† Parts required to convert between models.