

DOLI's NEW

ULTIMATE FLEXOMETER

(GOODRICH FLEXOMETER)



The System

At the time the Goodrich Flexometer was defined, it was hard to imagine, that an electronically controlled load could be kept constant. This was realised with a balance and weights. The Ultimate Flexometer is a multiprocessor system, which distributes the controlling jobs among the actions. Since all jobs and controls can be defined via software, actions like changing displacement by screwing, laying on weights, etc. aren't necessary anymore.

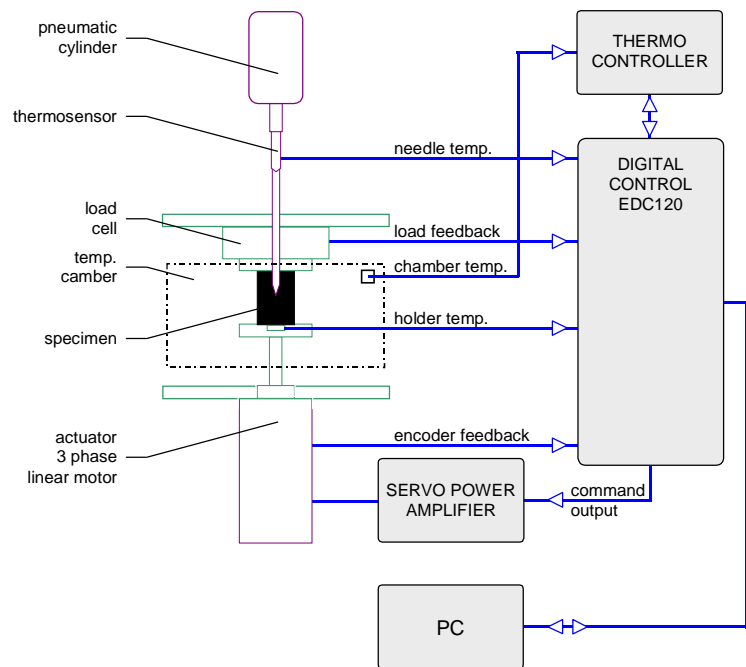

Draft 1: Function of the Ultimate Flexometer with 3-Phase-Linear-Motor.

Each specimen (max. 56) in the storage of the Ultimate Flexometer can be defined completely different to the prior specimen. Testing as well as specimen handling are fully automated.

Test duration

The test course for one specimen takes 70 minutes, including a preheat time of 30 minutes. However, as the Ultimate Flexometer offers (optionally) a maximum of 56 specimen storages, the test courses of the single specimens work into each other, so that one specimen will be in the preheat station, the second one will be tested in the test area, while the third one is in the specimen storage for cooling. Using all options, the system will offer about 38 hours of unattended testing!

Table 1: Overview of the possible test duration depending on the number of specimens.

	Preheat	Specimen 1		Specimen 2		... Specimen 56	
		test	cooling	test	cooling	test	cooling
Single times/min.	15 - 30	25	15	25	15	25	15
Test time per specimen/min.		40		40		40	
Max. total test time/min	30	70		110		... 2270	

The Specimen

The standard Flexometer specimen is defined in the standards ASTM 623, BS 903 part A50 and ISO 4666/3. The JIS K 6265 has a second specimen with 30mm Ø. Optionally, both specimen types can be served. Each specimen can be different here, too, meaning that the specimen holders are changed also.



Draft 2: Test area with specimen changer (green) at the lower holder.

Specimen Storage

There are no unknown specimens. Specimen data is transmitted via a LIMS or entered manually. After that, the specimens must be placed into the silo (with two different specimen sizes, the other silo is automatically inaccessible). The handling arm takes the specimen and puts it into the specimen storage, which is organized like a high shelf storage. The PC handles the storage administration. During storage time, the specimens are kept in position with a neglectable expenditure of load.

The specimen storage can bear a total of 56 specimens. It is divided as follows:

- One magazine with 11 storage places plus the height measurement station
- Optionally 3 further magazines with 15 storage places each

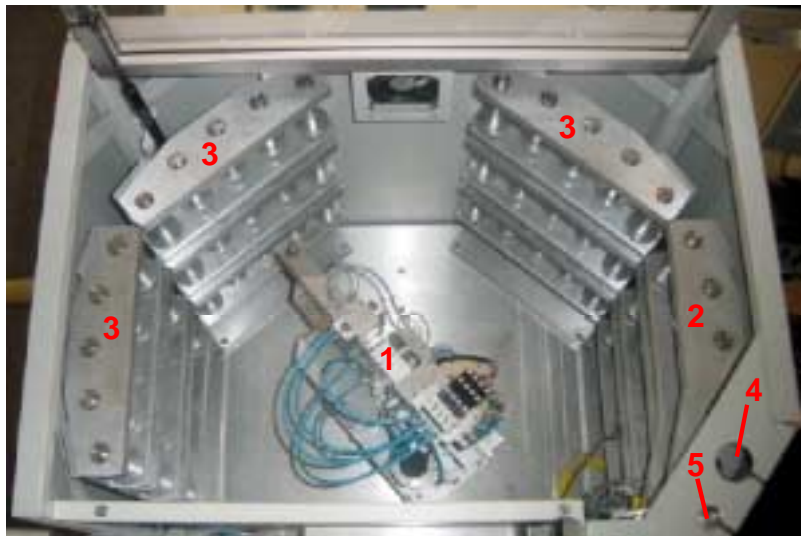
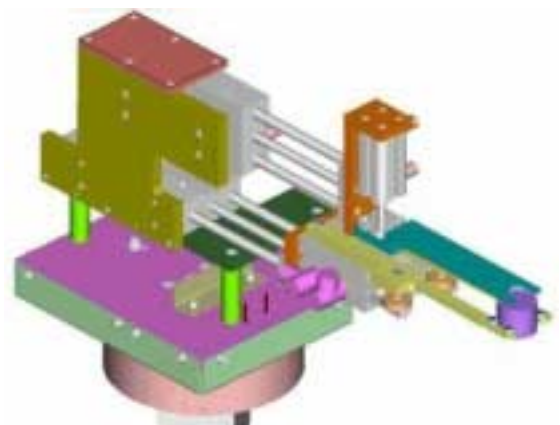

Fig.1: Inner view of the Ultimate Flexometer (from the top site). 1=handling-arm, 2=magazine (11 storages and height measurement station), 3=optional magazines (15 storages each), 4=silo (30mmØ), 5=silo (17.8mmØ)

The Handlingarm system

The handlingarm system can be moved in a circle as well as up and down. The handling arm has an additional finger to open the specimen mounting. The handling system serves all stations: Specimen silo 17,8mmØ and 30mmØ, all storages, height measurement station, preheat station, test area, waste disposal.



Draft 3: Handlingarm

Height measurement

For the Compression Set calculation a height measurement device, a storage place and a stop-watch (timer) are necessary. The Ultimate Flexometer measures the height h_0 prior to the test and the height h_e one hour after the test. During this hour, the specimen remains at ambient temperature within the storage. This guaranties an exact measurement of all specimens.

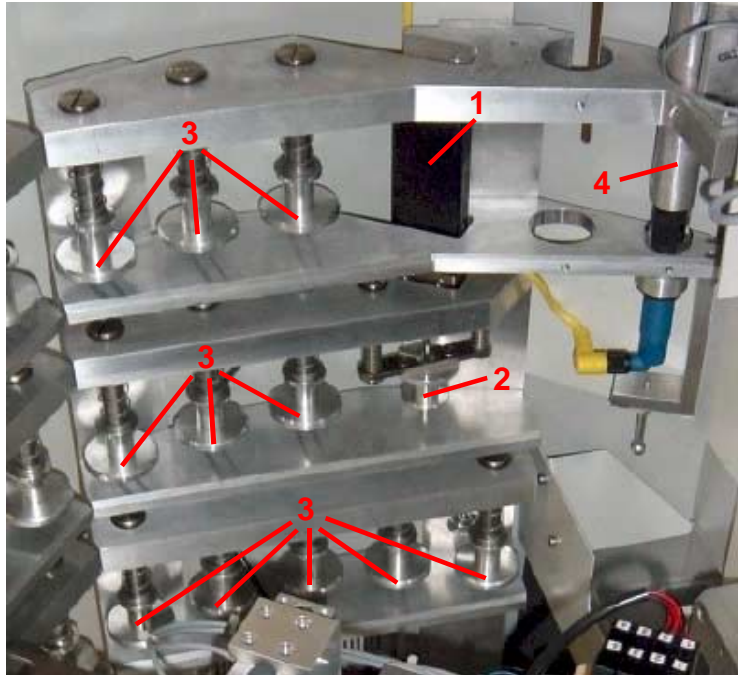

Fig.2: Inner view of the Ultimate Flexometer (trimmed area). 1=incremental encoder, 2=height measurement station, 3=specimen storages, 4=specimen silo

Temperature chamber

The temperature chamber has been optimized, so that the best values will be reached. Generally, there is a front door for manual handling as well as a rear door with automatic handling. The test area and the preheat station are surrounded by the temperature chamber.

Test Temperature and Puncture Needle

When the specimen is loaded, all necessary results as described in ASTM 623 will be generated: Creep, temperature rise, deformation and finally the center temperature. As there is no human influence in timing or changing of any parameters, a series of specimens is handled in absolutely the same way.

Temperature is measured by contact temperature in the center of the lower holder. The center temperature is measured by the pneumatically driven puncture needle at the end of the test. Optionally, a needle driven by a linear motor can be adjusted to stay inside the specimen during the test at one half of the average height position.

Since 1984, DOLI measures the center temperature with an acicular temperature sensor. The reason why we and our customers prefer to neither puncture the specimen before the end of the test nor leave the puncture needle inside the specimen during test, is not to damage the specimen.

Specimen output

The standard for the specimen output is: All test parameters are available, then put the specimen into the waste bin. Additionally, it is possible to give the order to the system to give out the specimen by batch selection. This offers the possibility to fill e.g. bags with the tested specimens batch by batch.

Software

The PC is the user Interface to the Flexometer. In 2001 DOLI did completely redesign the Software for the manual and fully automated Standard Flexometer and in 2002, the Ultimate Flexometer Software was designed in an WindowsTM environment. Data communication with LIM-Systems e.g. ECLIPSE has been realised.

The display of the temperature and deformation graph as well as the digital values is standard and always available.

In principle: The system is a Flexometer (constant strain) regarding ASTM 623 and ISO 4666.

In addition: Other specimens are possible, everything is adjustable. The Software is the medium to change the Ultimate Flexometer into a dynamic testing system.

In future: The next steps will be a constant stress Flexometer, different curve forms, viscoelastic properties, etc. The key for extending the Ultimate Flexometer is the Software.

At present: Updates and services can be handled via modem at any place in the world.

Constant Strain Test

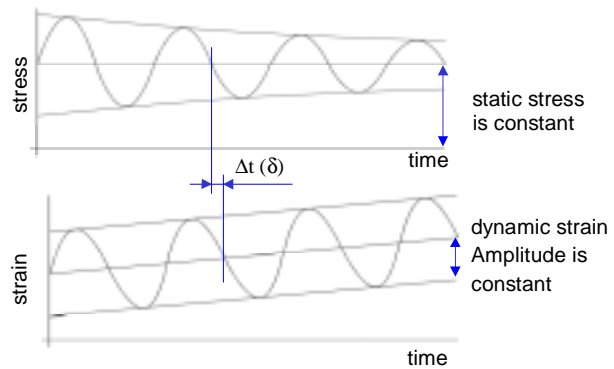

Dynamic waveforms

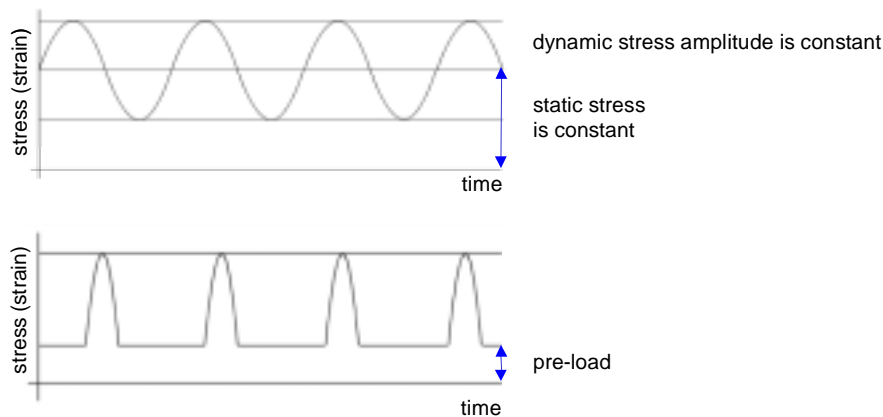

The Actuator

The idea was to develop a position and load controlled system, allowing the definition of all parameters via software and working fully automated as well as cover the Flexometer properties.

We had the following choice:

1. Eccentric drive

- mechanical control
- + low power
- + no water cooling

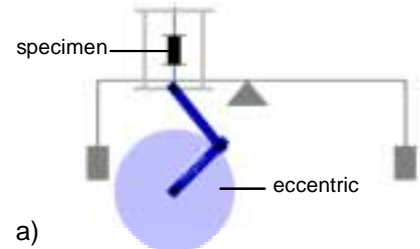

2. Hydraulic control

- high power consumption
- water cooling
- oil leakage
- noisy hydraulic power pack
- + high dynamic
- + electronic control

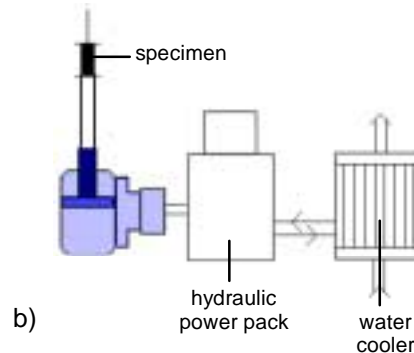

3. Linear motor

- + low power
- + no water cooling
- + high dynamic
- + electronic control
- + environmental friendly
- + low noise

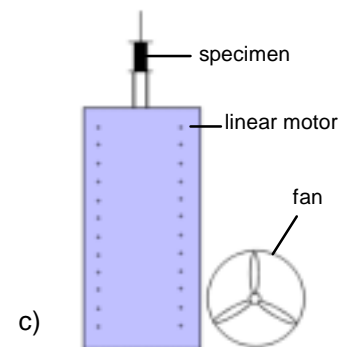

Draft 4: Different Flexometer actuators. a) Eccentric drive, b) Hydraulic control, c) Linear motor.

Of course, the best choice is

- the Linear motor with its high dynamic characteristics. The load is selected to reach the maximum Flexometer standards with 30Hz and 6.4 mm stroke (3.2mm amplitude). For further applications, a maximum of 50Hz is possible with 1mm amplitude. A fan is used to cool the system, because the generated heat, depending on the driven load, can be some 100 Watts.

Specifications

Compressed-air supply: 6 bar, 1l/min

Electric power supply: TN-S $\Delta 400V_{AC}$, 50Hz, 1.5kW
 (for USA, Canada: TN-S $\Delta 200...210V_{AC}$, 60Hz, 1.5kW; U_N 120V_{AC}, 60Hz)

Stromversorgung / Power Supply

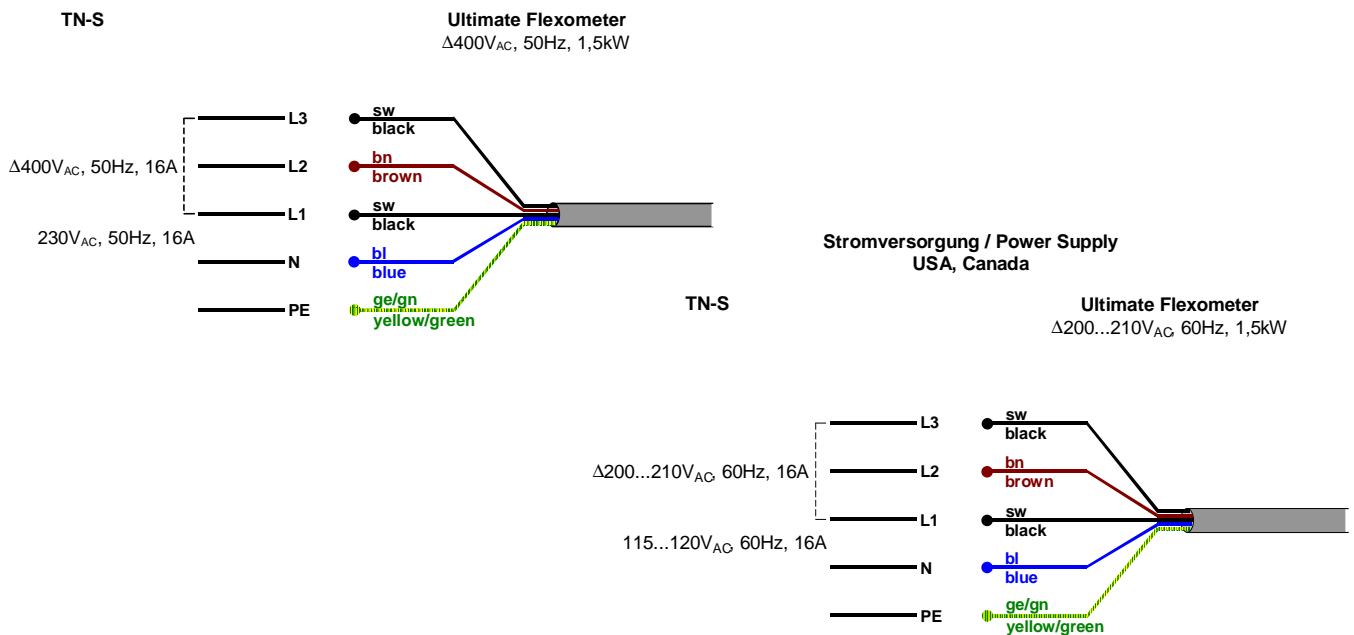

Dimensions:

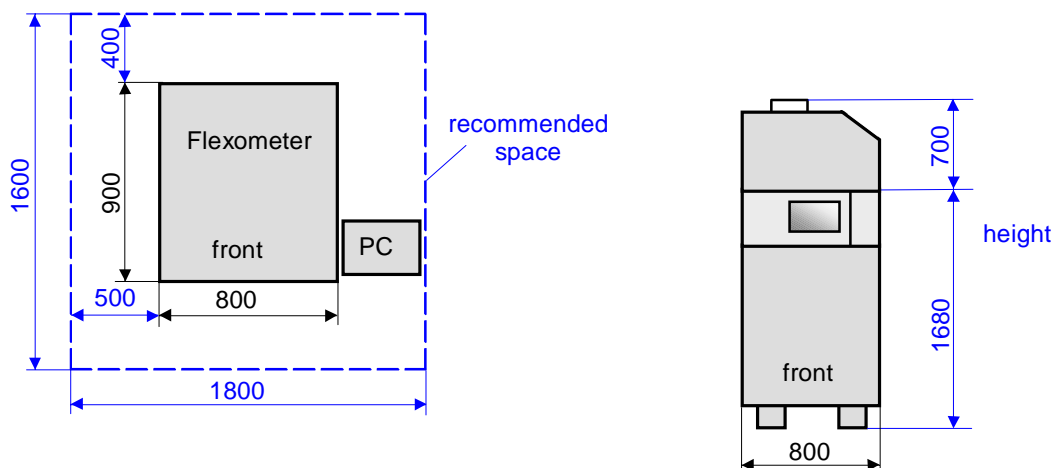

Service

All Flexometers are delivered with a modem inside the PC. That enables DOLI to provide fast service anywhere in the world. We will see in our service software, if there are any problems. Then, we can advice the on-site service or the customer, how to get the system working again.



The Advantages for you, using

ULTIMATE COMPRESSION FLEXOMETER

1. Results are available directly and without staff influence.
2. The Flexometer works all day, at night and on Sundays also.
3. Unpopular handling and adjusting are eliminated.
4. Personell can do other control work, which requires real human control.
5. Temperature measurements are done with the puncture needle immediately, temperature loss is eliminated.
6. The Flexometer will fit into a CAQ system by reporting data to a Host computer, e.g. DAISY from ECLIPSE, to suit your needs.
7. The Ultimate Flexometer offers the latest actuator technique, the 3-phase-linear-motor.
8. The 3-phase-linear-motor is very environmental friendly. It has a low power consumption rate, needs no water cooling and works very quietly.
9. The advantages can be calculated in money.

Qualitest USA LC

Tel.: 1.877.884.TEST (8378)

Fax: 954.697.8211

Internet: www.WorldofTest.com

Qualitest International Inc. (Canada)

Tel.: 905.944.9825

Fax: 905.944.0304

Email: info@qualitest-inc.com